

MODULE 0: PREREQUISITE REVIEW

Samantha Ramirez, MSE



OBJECTIVE

- Review concepts from Statics and Engineering Materials in preparation for a pre-test.

FORCES & MOMENTS

- A **FORCE** is the action of one body on another.
- Forces always exist in equal magnitude, opposite direction pairs.
- A **MOMENT** is generated when a force does not have an equal and opposite force applied in its line of action.
- Moments are a measure of a force's tendency to cause a body to rotate about a specific point or axis.

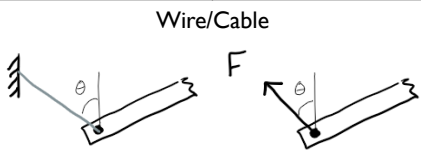
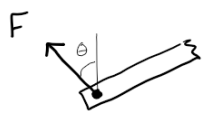
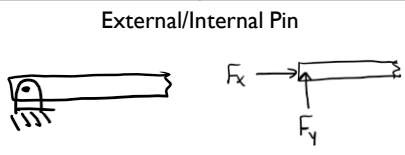
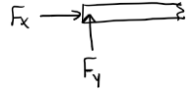
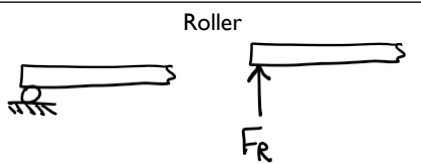
CONNECTIONS & REACTIONS

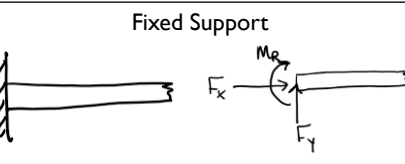
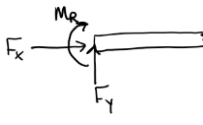
Connection	Reaction	Connection	Reaction
 <p>Wire/Cable</p>	 <p>1 Reaction</p>	 <p>External/Internal Pin</p>	 <p>2 Reactions</p>
 <p>Roller</p>	 <p>1 Reaction</p>	 <p>Fixed Support</p>	 <p>3 Reactions</p>

- If the support prevents translation in a given direction, then a force must be developed on the member in that direction.
- Likewise, if rotation is prevented, a couple moment must be exerted on the member.

EXTERNAL LOADS

- Can be applied to a body as distributed or concentrated surface loadings or as body forces which act throughout the volume.

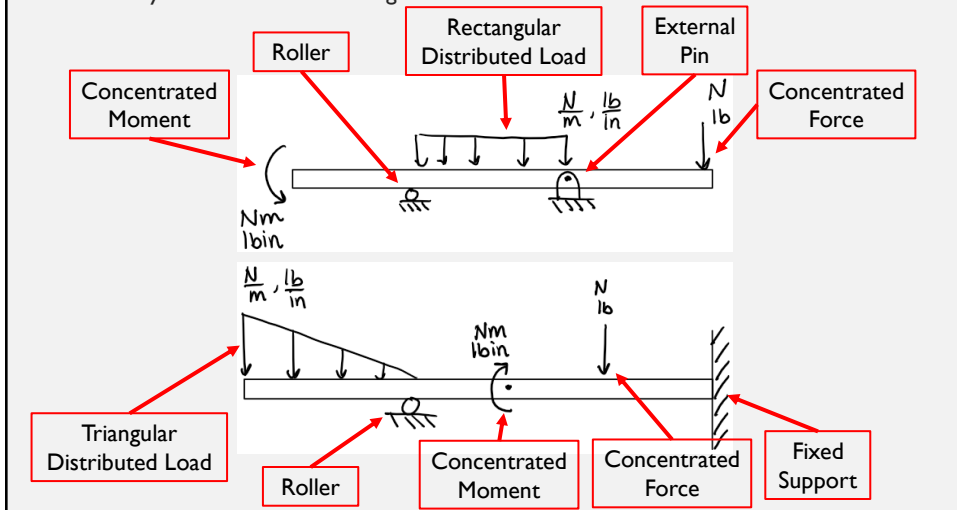

TWO-FORCE MEMBERS

- Two-force member
 - A member that has pin supports at both ends and is subjected to no load in between is called a two-force member.
- Two-force principal
 - If only two forces act on a body that is in equilibrium, these two forces must be equal in magnitude and opposite in sense.
- Line of Action
 - The reaction forces of a two-force member are directed along the line of action between the two pinned ends.

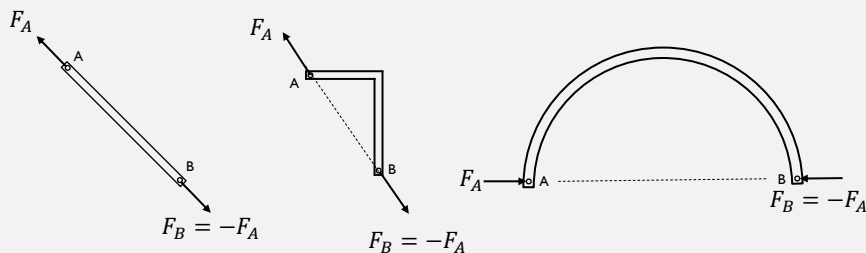

REDUCING DISTRIBUTED LOADS

- Linear distributed loadings produce a resultant force having a magnitude equal to the area under the load diagram, and having a location that passes through the centroid of this area.

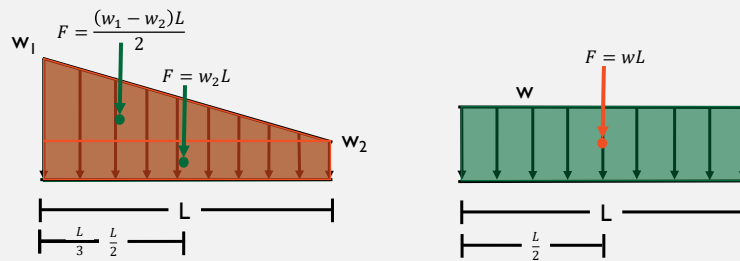

STATIC EQUILIBRIUM EQUATIONS

$$+ \sum F_x = 0$$

$$+ \sum M_x = 0$$

$$+ \sum F_y = 0$$

$$+ \sum M_y = 0$$

$$+ \sum F_z = 0$$

$$+ \sum M_z = 0$$

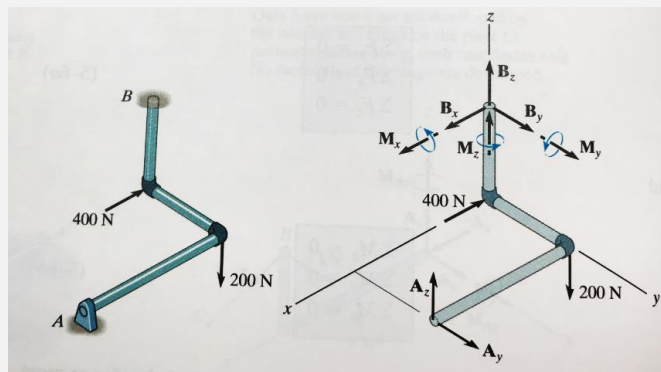

STRESS-STRAIN DIAGRAM

- The most important result from the tension test is the stress-strain diagram (σ - ϵ diagram).
- Nominal or engineering stress and strain are used to create a σ - ϵ diagram.

- E: Young's Modulus
- S_y : Yield Strength
- UTS: Ultimate Tensile Strength
- ϵ_f^T : Total Strain at Failure
- ϵ_f^P : Plastic Strain at Failure

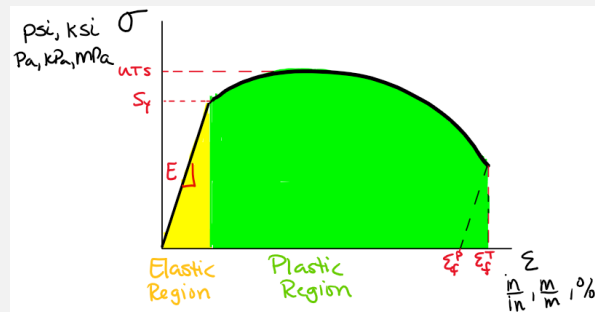

SOLVING FOR CHANGES IN DIMENSIONS

- $\sigma = \frac{F}{A}$
- $\epsilon_{Long} = \frac{\Delta L}{L_o}$
- $E = \frac{\sigma}{\epsilon_{Long}}$ (Only used if $\sigma < S_y$)
- $\nu = -\frac{\epsilon_{Lat}}{\epsilon_{Long}}$
- $\epsilon_{Lat} = \frac{\Delta d}{d_o}$
- $G = \frac{E}{2(1+\nu)}$ (Only if material type and alloy is unknown)



- Knowns:
 - Original length, L_o
 - Original diameter, d_o
 - Material type and alloy
 - E & ν
 - External force, F

EXAMPLE I

- Determine the reaction at point A.

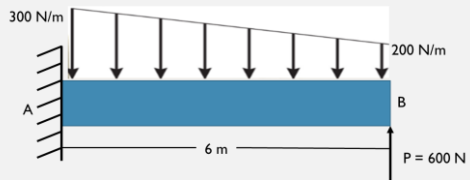
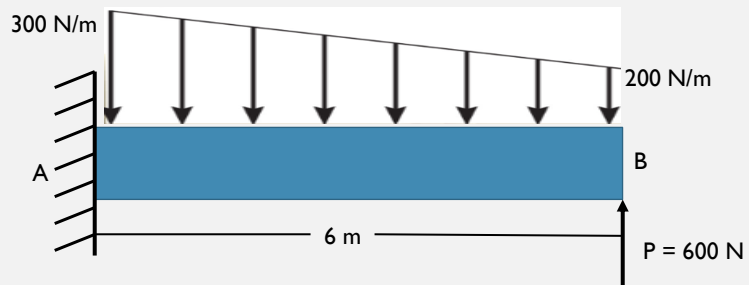

EXAMPLE 2

- Determine the reaction at point A.

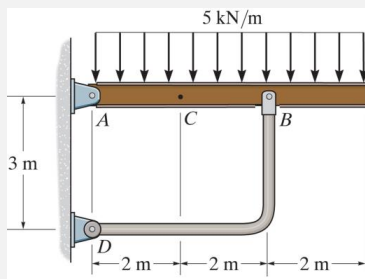
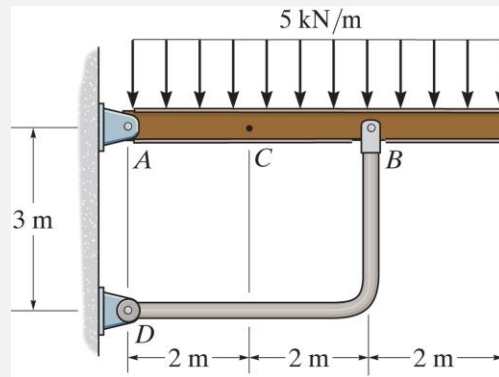

EXAMPLE 3

- Determine the reactions at point C.

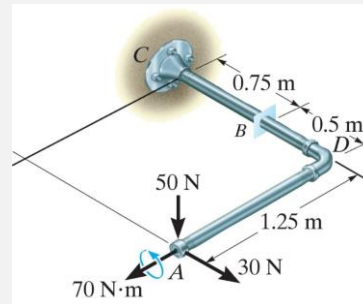
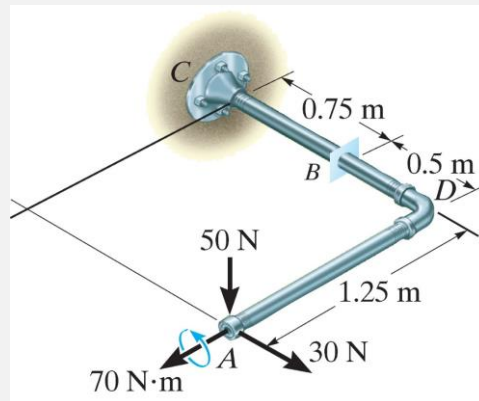

EXAMPLE 4

- The aluminum rod is 3 ft long and has a diameter of 0.15 in. If an axial load of 3.25 kip is applied to it, determine the change in its length and the change in its diameter. Note: $E_{AL} = 10 \times 10^3$ ksi

