

# Chapter 6: Impedance Bond Graphs

Samantha Ramirez

## Preview Questions

What connections are there between linear algebra and differential equations?

How can you transform a system of differential equations into an algebraic formulation?

What advantages, if any, would an algebraic model have over differential equations?

Are there any concepts from electric circuits that you could generalize to facilitate synthesizing such models?

## Objectives & Outcomes

### Objectives:

1. To understand relations between state-space and transfer-function representations of linear, time-invariant systems,
2. To understand the synthesis and use impedance bond graphs, and
3. To be able to use alternative methods to derive transfer functions for systems that may require advanced formulation due to sign changes or complex bond graph structures.

### Outcomes: Upon completion, you will

1. be able to transition between state-space and transfer-function representations of dynamic systems,
2. be able to synthesize impedance bond graphs of mechanical, electrical, and hydraulic systems, and
3. be able to derive transfer functions for dynamic systems using bond graphs as an aid.

## Laplace Transforms and the State Space

$$\begin{aligned}\dot{\mathbf{x}} &= \mathbf{Ax} + \mathbf{Bu} \\ \mathbf{y} &= \mathbf{Cx} + \mathbf{Du}\end{aligned}$$

Laplace transforms can be applied to the state-space to generate the transfer functions,

$$\begin{aligned}s\mathbf{X}(s) &= \mathbf{AX}(s) + \mathbf{BU}(s) \\ \mathbf{Y}(s) &= \mathbf{CX}(s) + \mathbf{DU}(s)\end{aligned}$$

Ultimately, we wish to get the transfer functions,  $G(s)$ , relating the outputs,  $Y(s)$ , to the inputs,  $U(s)$ , such that

$$\mathbf{Y}(s) = \mathbf{G}(s)\mathbf{U}(s)$$

Solve for  $\mathbf{X}(s)$ ,

$$s\mathbf{X}(s) - \mathbf{AX}(s) = (s\mathbf{I} - \mathbf{A})\mathbf{X}(s) = \mathbf{BU}(s) \rightarrow \mathbf{X}(s) = (s\mathbf{I} - \mathbf{A})^{-1}\mathbf{BU}(s)$$

and substitute

$$\mathbf{Y}(s) = \mathbf{C}(s\mathbf{I} - \mathbf{A})^{-1}\mathbf{BU}(s) + \mathbf{DU}(s) = [\mathbf{C}(s\mathbf{I} - \mathbf{A})^{-1}\mathbf{B} + \mathbf{D}]\mathbf{U}(s)$$

to derive  $G(s)$

$$\mathbf{G}(s) = \mathbf{C}(s\mathbf{I} - \mathbf{A})^{-1}\mathbf{B} + \mathbf{D}$$

# Matrices

Identity Matrix

$$I = \begin{bmatrix} 1 & 0 & 0 \\ 0 & 1 & 0 \\ 0 & 0 & 1 \end{bmatrix}$$

Inverse Matrix

$$A = \begin{bmatrix} a & b \\ c & d \end{bmatrix}$$

$$\begin{aligned} A^{-1} &= \frac{1}{|A|} \begin{bmatrix} d & -b \\ -c & a \end{bmatrix} \\ &= \frac{1}{ad-bc} \begin{bmatrix} d & -b \\ -c & a \end{bmatrix} \end{aligned}$$

## Example 6.1

Take for Example the simple mass-spring-damper depicted in Figure 6.2. Derive the transfer functions for the system.

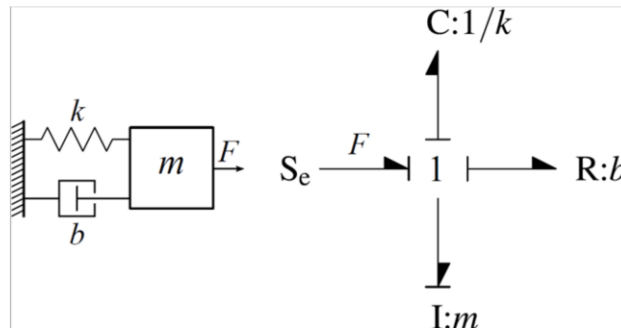

$$\begin{bmatrix} \dot{x} \\ \dot{p} \end{bmatrix} = \begin{bmatrix} 0 & 1/m \\ -k & -b/m \end{bmatrix} \begin{bmatrix} x \\ p \end{bmatrix} + \begin{bmatrix} 0 \\ 1 \end{bmatrix} F(t)$$
$$y = x = [1 \quad 0] \begin{bmatrix} x \\ p \end{bmatrix} + 0 \cdot F(t)$$

## Example 6.2

Remember the mass-spring-damper system from Example 3.11. Figure 6.2(b) shows four energy storing elements in integral causality. The output of interest are the positions of the two masses,  $x_1$  and  $x_2$ . Convert the state-space models to transfer functions relating each of the displacement to the input force.

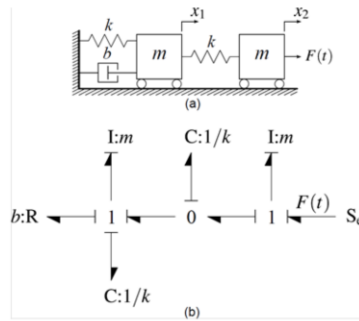

$$\begin{bmatrix} \dot{x}_1 \\ \dot{p}_1 \\ \delta \\ \dot{p}_2 \end{bmatrix} = \begin{bmatrix} 0 & 1/m & 0 & 0 \\ -k & -b/m & k & 0 \\ 0 & -1/m & 0 & 1/m \\ 0 & 0 & -k & 0 \end{bmatrix} \begin{bmatrix} x_1 \\ p_1 \\ \delta \\ p_2 \end{bmatrix} + \begin{bmatrix} 0 \\ 0 \\ 0 \\ 1 \end{bmatrix} F(t)$$







$$\begin{bmatrix} x_1 \\ x_2 \end{bmatrix} = \begin{bmatrix} 1 & 0 & 0 & 0 \\ 1 & 0 & 1 & 0 \end{bmatrix} \begin{bmatrix} x_1 \\ p_1 \\ \delta \\ p_2 \end{bmatrix} + \begin{bmatrix} 0 \\ 0 \end{bmatrix} F(t)$$

## Basic 1-Port Impedances







Domain	Element	Effort-Flow Relation	Impedance
General	R	$e(t) = Rf(t) \leftrightarrow e(s) = Rf(s)$	$Z_R = \frac{e(s)}{f(s)} = R$
	C	$e(t) = \frac{1}{C} \int f(t) dt \leftrightarrow e(s) = \frac{1}{Cs} f(s)$	$Z_C = \frac{e(s)}{f(s)} = \frac{1}{Cs}$
	I	$e(t) = I \frac{df(t)}{dt} \leftrightarrow e(s) = Isf(s)$	$Z_I = \frac{e(s)}{f(s)} = Is$



# Element Impedances

	Element Type	Component	Force-Velocity	Impedance $Z(s)=F(s)/V(s)$
Mechanical Translation	R-Element	Damper 	$f(t) = bv(t)$ $F(s) = bV(s)$	$b$
	C-Element	Spring 	$f(t) = k \int v(t) dt$ $F(s) = \frac{k}{s} V(s)$	$\frac{k}{s}$
	I-Element	Mass 	$f(t) = m \frac{dv(t)}{dt}$ $F(s) = msV(s)$	$ms$
	Element Type	Component	Torque-Velocity	Impedance $Z(s)=T(s)/\Omega(s)$
Mechanical Rotation	R-Element	Bearing 	$\tau(t) = B\omega(t)$ $T(s) = B\Omega(s)$	$B$
	C-Element	Spring 	$\tau(t) = \kappa \int \omega(t) dt$ $T(s) = \frac{\kappa}{s} \Omega(s)$	$\frac{\kappa}{s}$
	I-Element	Inertia 	$\tau(t) = J \frac{d\omega(t)}{dt}$ $T(s) = Js\Omega(s)$	$Js$

## Element Impedances

		Element Type	Component	Voltage-Current	Impedance $Z(s)=F(s)/M(s)$
Electrical Circuits	R-Element	Resistor		$e(t) = Ri(t)$ $E(s) = RI(s)$	$R$
	C-Element	Capacitor		$e(t) = \frac{1}{C} \int i(t) dt$ $E(s) = \frac{1}{Cs} I(s)$	$\frac{1}{Cs}$
	I-Element	Inductor		$e(t) = L \frac{di(t)}{dt}$ $E(s) = LsI(s)$	$Ls$
		Element Type	Component	Pressure-Flow	Impedance $Z(s)=F(s)/M(s)$
Hydraulic Circuits	R-Element	Valve		$P(t) = R_f Q(t)$ $P(s) = R_f Q(s)$	$R_f$
	C-Element	Accumulator		$P(t) = \frac{1}{C_f} \int Q(t) dt$ $P(s) = \frac{1}{C_f s} Q(s)$	$\frac{1}{C_f s}$
	I-Element	Inertia		$P(t) = I_f \frac{dQ(t)}{dt}$ $P(s) = I_f s Q(s)$	$Ls$

## Impedance Bond Graph Synthesis

Same process as regular bond graphs

Use impedances in place of R-, C-, and I-elements

Do not include causal strokes

Do not use sources

    Instead label the Laplace transform of the supplied effort or flow

## Example 6.3

Recall the mass-spring-damper problem from Example 6.2. Generate the impedance bond graph for this system.

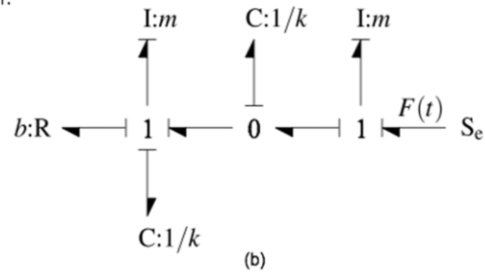
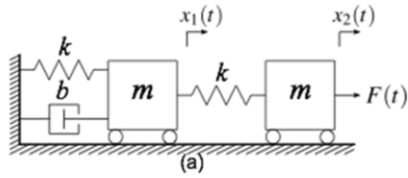

## Example 6.4

Recall the circuit for Example 3.5. Create a regular bond graph and compare to an impedance bond graph.

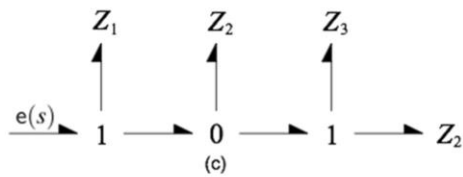
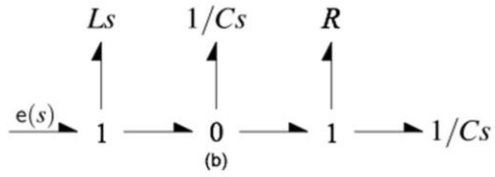
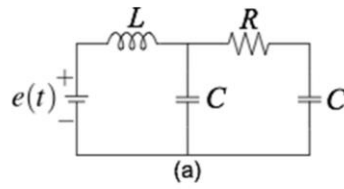

## Challenge Problem

Recall the bond graph for the challenge problem. Convert the bond graph to an impedance bond graph.

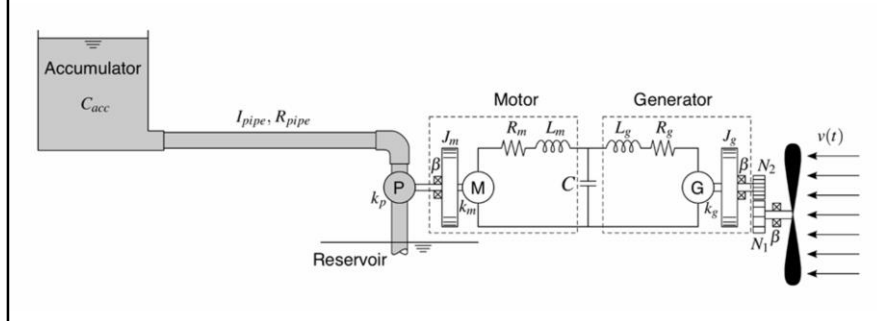

## Transfer Function Derivation

1. Identify the desired system inputs and outputs
2. Formulate a strategy
3. Iteratively condense (simplify) using equivalencies

## Junctions, Transformers, and Gytrators (For Condensing)

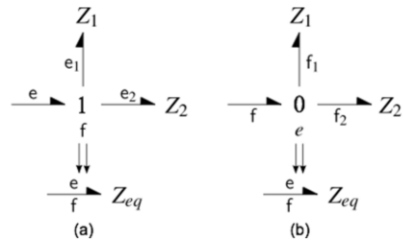

Item	Impedance
1-Junction	$Z_{eq} = Z_1 + Z_2$
0-Junction	$Z_{eq} = \frac{Z_1 Z_2}{Z_1 + Z_2}$
Transformer	$Z_{eq} = n^2 Z$
Gytrator	$Z_{eq} = \frac{r^2}{Z}$

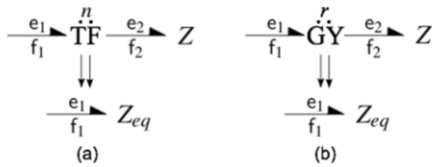



## Example 1

Generate an impedance bond graph. Reduce the resulting impedance bond graph to a single power bond.

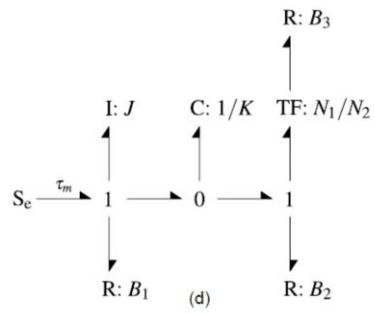
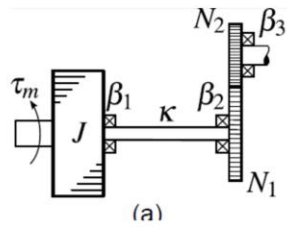

# Effort and Flow Dividers

Item	Mathematical Relation
Effort Divider	$\frac{e_{out}}{e_{in}} = \frac{Z_2}{Z_1 + Z_2}$
Flow Divider	$\frac{f_{out}}{f_{in}} = \frac{Z_1}{Z_1 + Z_2}$

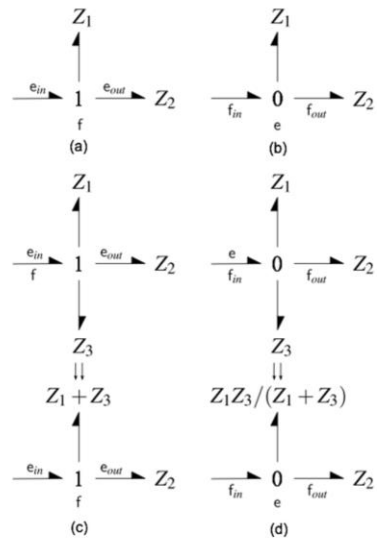

## Example 2

Convert the following bond graph to an impedance bond graph.  
Determine the transfer functions for the following  
relationships:  $\frac{f_1}{f}$ ,  $\frac{f_2}{f}$ ,  $\frac{e_1}{\tau_m}$ ,  $\frac{e_2}{\tau_m}$ .

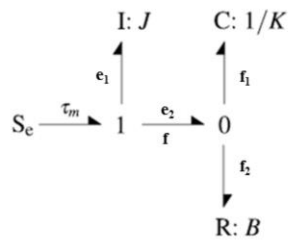

## Example 6.5 A Mass-Spring-Damper System

Derive a transfer function using an impedance bond graph.

$$\begin{aligned} \frac{x_2(s)}{F(s)} &= \frac{1}{sZ_{total}} \\ &= \frac{ms^2 + bs + 2k}{m^2s^4 + mbs^3 + 3mks^2 + bks + k^2} \\ \frac{x_1(s)}{F(s)} &= \frac{x_1(s)x_2(s)}{x_2(s)F(s)} \\ &= \frac{k}{m^2s^4 + mbs^3 + 3mks^2 + bks + k^2} \end{aligned}$$

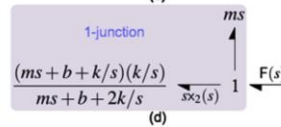
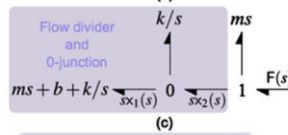
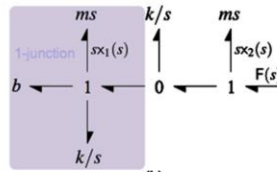
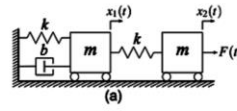

$$\frac{(ms + b + k/s)(k/s)}{ms + b + 2k/s} + ms \frac{F(s)}{sx_2(s)}$$

## Example 6.6 An Electric Circuit

Derive the transfer functions relating the voltages  $e_1(s)$  and  $e_2(s)$  to the input voltage  $e(t)$ .

$$\frac{e_1(s)}{e(s)} = \frac{RCs + 1}{LRC^2s^3 + 2LCs^2 + RCs + 1}$$

$$\frac{e_2(s)}{e(s)} = \frac{1}{LRC^2s^3 + 2LCs^2 + RCs + 1}$$

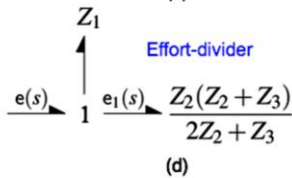
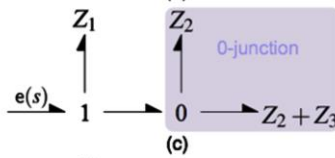
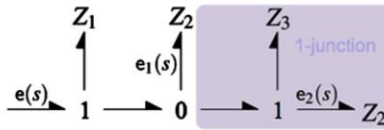
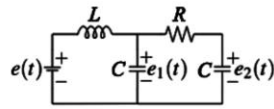

## Example 6.7 A PMDC Motor

Derive a transfer function using an impedance bond graph to determine the response of the output torque,  $\tau_2(t)$ , relative to the input voltage,  $e_{in}(t)$ .

$$\frac{T_2(s)}{e_{in}(s)} = \frac{k_m n B}{JRs + n^2 BR + k_m^2}$$

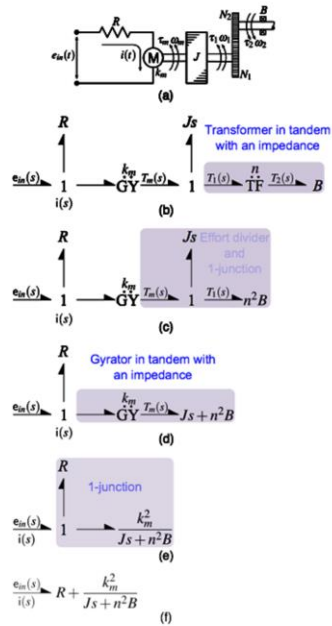

## Review Problem 1

Recall the bond graph synthesized in Chapter 3 for the given system. Derive transfer functions relating the displacements of both masses to the input force  $F(t)$ .

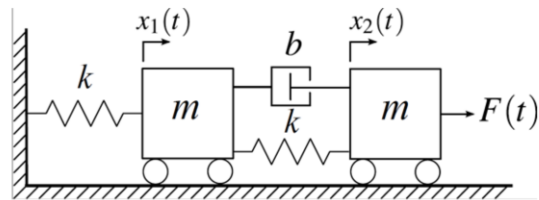

## Review Problem 2

Recall the bond graph synthesized in Chapter 3 for the given system. Derive the transfer functions relating output angular velocity to the input voltage,  $e_{in}(t)$ .

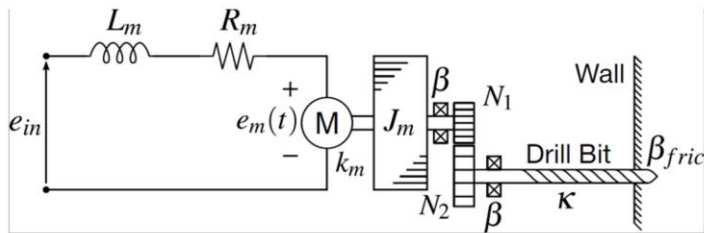



## Review Problem 3

Recall the bond graph synthesized in Chapter 3 for the given system. Derive the transfer function relating the displacement of the mass to the input voltage,  $e_{in}(t)$ .

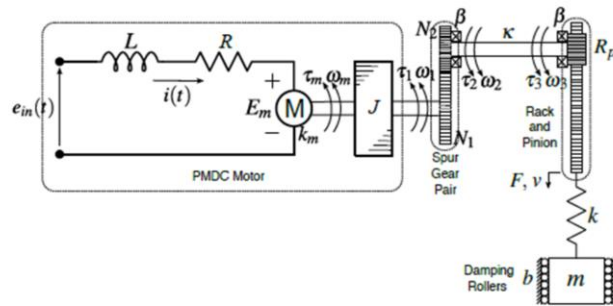

# Challenge Problem

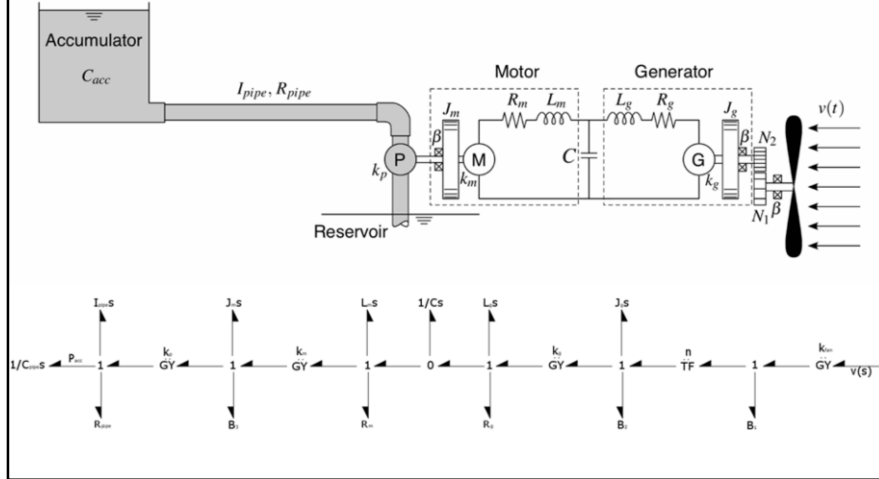

## Challenge Problem

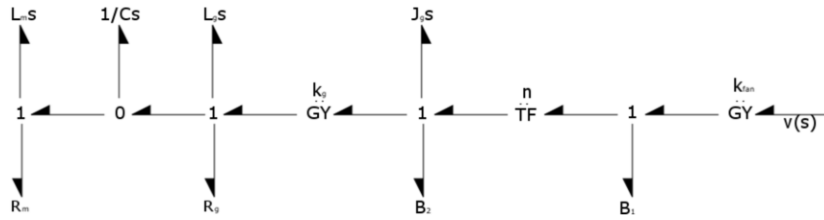

## Challenge Problem

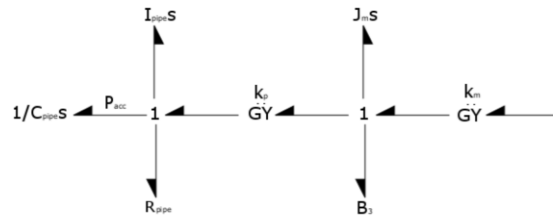

## Model Transformations Using MATLAB

Function	Description
ss2tf(A,B,C,D)	converts from state space to transfer function
tf2ss(num,den)	converts from transfer function to state space

### Example 6.11

Use MATLAB to convert the state-space representation of Example 6.2 assuming that the mass, damping constants, and spring rate are 10 kg, 20 N-m/s, and 60 N/m.

$$\begin{bmatrix} \dot{x}_1 \\ \dot{p}_1 \\ \dot{\delta} \\ \dot{p}_2 \end{bmatrix} = \begin{bmatrix} 0 & 1/m & 0 & 0 \\ -k & -b/m & k & 0 \\ 0 & -1/m & 0 & 1/m \\ 0 & 0 & -k & 0 \end{bmatrix} \begin{bmatrix} x_1 \\ p_1 \\ \delta \\ p_2 \end{bmatrix} + \begin{bmatrix} 0 \\ 0 \\ 0 \\ 1 \end{bmatrix} F(t)$$

$$\begin{bmatrix} x_1 \\ x_2 \end{bmatrix} = \begin{bmatrix} 1 & 0 & 0 & 0 \\ 1 & 0 & 1 & 0 \end{bmatrix} \begin{bmatrix} x_1 \\ p_1 \\ \delta \\ p_2 \end{bmatrix} + \begin{bmatrix} 0 \\ 0 \end{bmatrix} F(t)$$

## Summary

Laplace transforms can be applied to the differential equations derived from a bond graph to determine transfer functions. This is especially concise if applied to the state-space form of the resulting equations. However, for systems with more than three states, this can be cumbersome to implement analytically and many times must be done so with the aid of symbolic math software.

The concept of impedance used for electric circuits analysis can be adapted to derive equivalent mechanical impedances. The impedance can be derived by applying the transfer function concept to the effort-flow relations on linear I-, R-, and C-elements. The impedance of an I-, R-, or C-element is the ratio of effort to flow after taking the Laplace transform of the constitutive relation and assuming initial conditions are zero.

Impedance bond graphs are synthesized in much the same manner as regular bond graphs with a few exceptions: (1) I-, R-, and C-elements are replaced with their equivalent impedances, (2) causal strokes are unnecessary, and (3) sources are replaced simply by a bond labeled with the Laplace transform of the associated effort or flow.

Impedances attached to 1-junctions sum like resistances in series.

Impedances attached to 0-junctions sum like resistances in parallel.

Equivalent impedances for transformers and gyrators in tandem with an impedance can be readily determined in terms of the modulus and the attached impedance .

## Summary Continued

A 1-junction can be used as an effort divider to determine the transfer function relating the effort on any attached bond to the effort on the primary bond.

A 0-junction can be used as a flow divider to determine the transfer function relating the flow on any attached bond to the flow on the primary bond.

Sign changes can be readily accounted for in impedance bond graphs. The basic relations for equivalent impedance remain the same. However, to maintain the sign change the flow on the primary bond of a 1-junction with a sign change is negated, and the effort on the primary bond of a 0-junction with a sign change is negated. For effort and flow dividers, the overall relations are negated.

The basic steps to deriving transfer functions directly from an impedance bond graph are: (1) identify the inputs and outputs to determine the necessary transfer functions, (2) formulate a strategy to determine intermediate steps, and (3) iteratively condense the impedance bond graph using equivalencies while solving for any necessary intermediate transfer functions.

An alternate approach to deriving transfer functions from bond graphs is to use the summation of effort and summation of flow equations resulting from junctions to derive a set of linear algebraic equations in terms of unknown efforts and flows in the  $s$ -domain that can be solved simultaneously using Linear Algebra. The basic procedure is: (1) label junctions with distinct efforts and flows, (2) derive remaining unknown efforts and flows using impedance relations, (3) derive summation of effort and summation of flow equations, (4) arrange the resulting equations into set linear algebraic equations in terms of the efforts and flows, and (5) solve the equations simultaneously.

MATLAB includes several commands for converting between state-space and transfer-function representations.