

## Chapter 8 Lecture Problems

### Problem 8-4

The tank of the air compressor is subjected to an internal pressure of 90 psi. If the internal diameter of the tank is 22 in, and the wall thickness is 0.25 in, determine the stress components acting at point A. Draw a volume element of the material at this point, and show the results on the element.

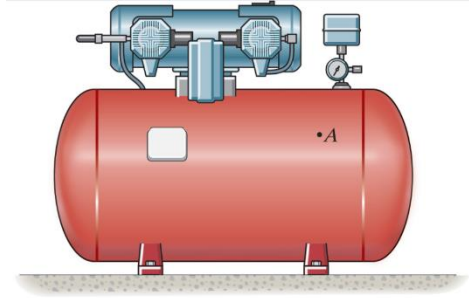

## Chapter 8 Lecture Problems

### Problem 8-10

The A-36 steel band is 2 in wide and is secured around the smooth rigid cylinder. If the bolts are tightened so that the tension in them is 400 lb, determine the normal stress in the band, the pressure exerted on the cylinder, and the distance half the band stretches.

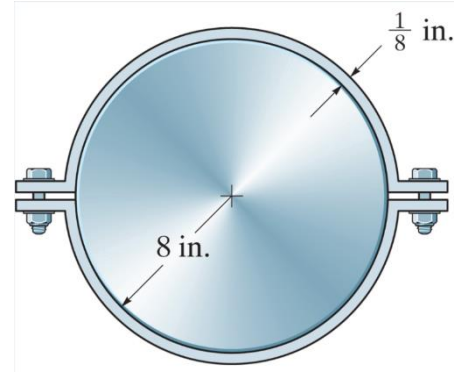

## Chapter 8 Lecture Problems

### Problem 8-12

A pressure-vessel head is fabricated by gluing the circular plate to the end of the vessel as shown. If the vessel sustains an internal pressure of 450 kPa, determine the average shear stress in the glue and the state of stress in the wall of the vessel.

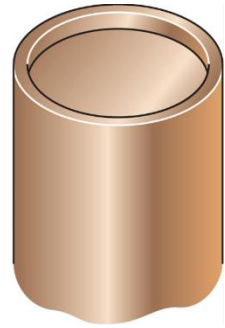
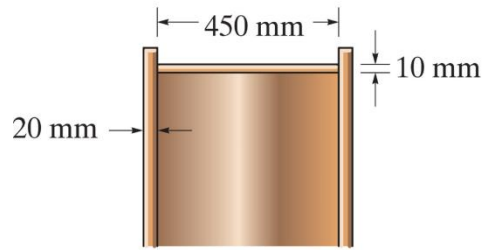

## Chapter 8 Lecture Problems

### Problem F8-4

Determine the magnitude of the load  $P$  that will cause a maximum normal stress of 30 ksi in the link along section a-a.

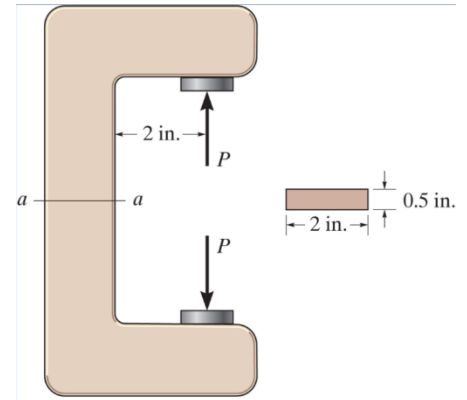

## Chapter 8 Lecture Problems

### Problem F8-5

The beam has a rectangular cross section and is subjected to the loading shown. Determine the state of stress at point B. Show the results in a differential element at the point.

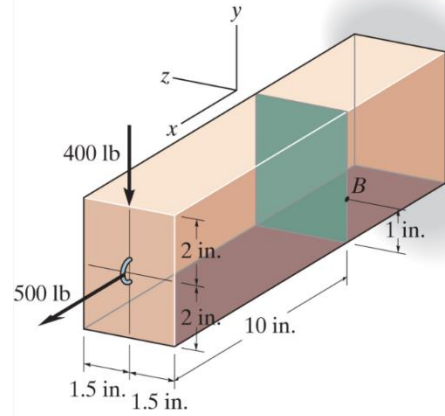

## Chapter 8 Lecture Problems

### Problem F8-6

Determine the state of stress at point A on the cross section of the pipe assembly at section a-a. Show the results in a differential element at the point.

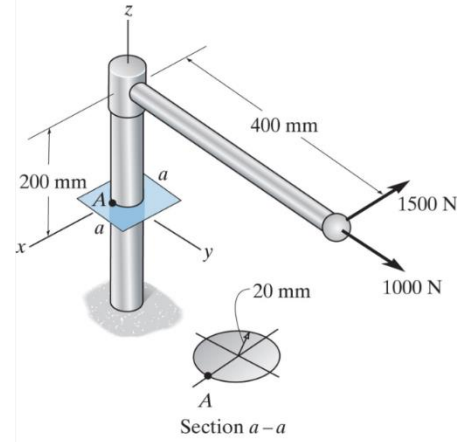

## Chapter 8 Lecture Problems

### Problem F8-8

Determine the state of stress at point A on the cross section of the shaft at section a-a. Show the results in a differential element at the point.

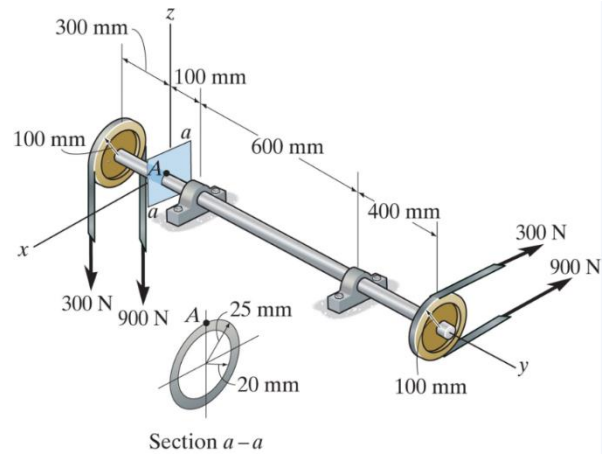

## Chapter 8 Lecture Problems

### Problem 8-30

The rib-joint pliers are used to grip the smooth pipe C. If the force of 100 N is applied to the handles, determine the state of stress at points A and B on the cross section of the jaw at section a-a. Indicate the results on an element at each point.

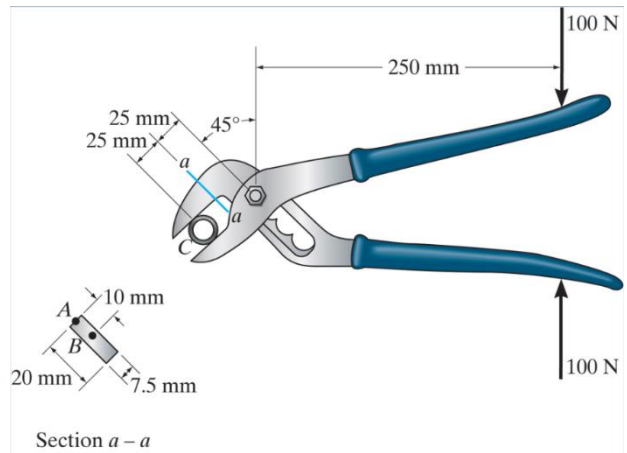



## Chapter 8 Lecture Problems

### Problem 8-57

The sign is subjected to the uniform wind loading. Determine the stress components at points A and B on the 100 mm diameter supporting post. Show the results on a volume element located at each of these points.

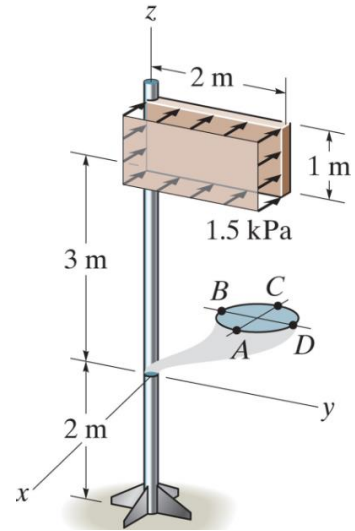

## Chapter 8 Lecture Problems

### Example 1

Determine the state of stress at point C of the cross-section at section c-c. Section c-c is 3 ft from point A and point C is 2 in from the bottom of the cross section. Sketch the results on a volume element.

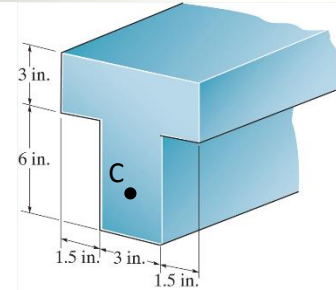
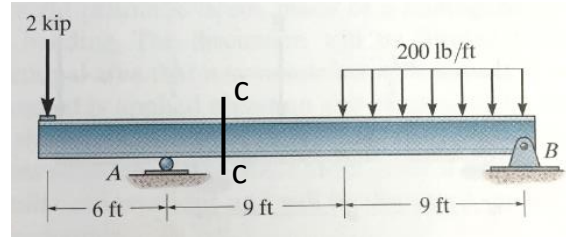

## Chapter 8 Lecture Problems

### Problem 8-47, 48, 49

The bent shaft is fixed in the wall at A. If a force  $F$  of 12 lb is applied at B, determine the stress components at points D and E. Show the results on a differential element located at each of these points.  $\theta = 0^\circ, 90^\circ,$  and  $45^\circ$ .

