

University of Texas – Rio Grande Valley Engineering Graphics

Dimensions are in Inches – Save all parts as (.prt)

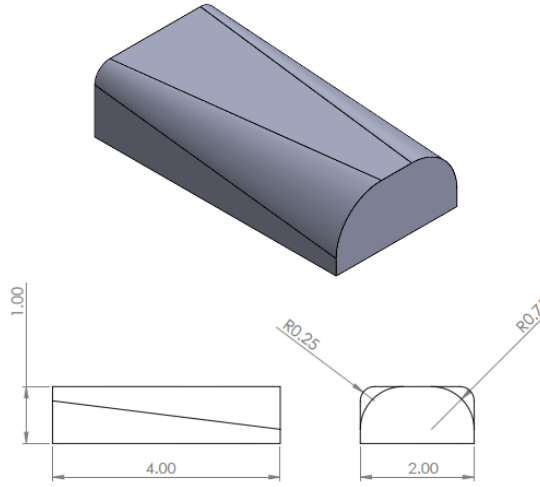

Use the Variable Radius Fillet feature to smooth the edges of the block



Revolve a spline as a Thin Feature
Manipulate the spline to create your own shape, but use the given dimensions

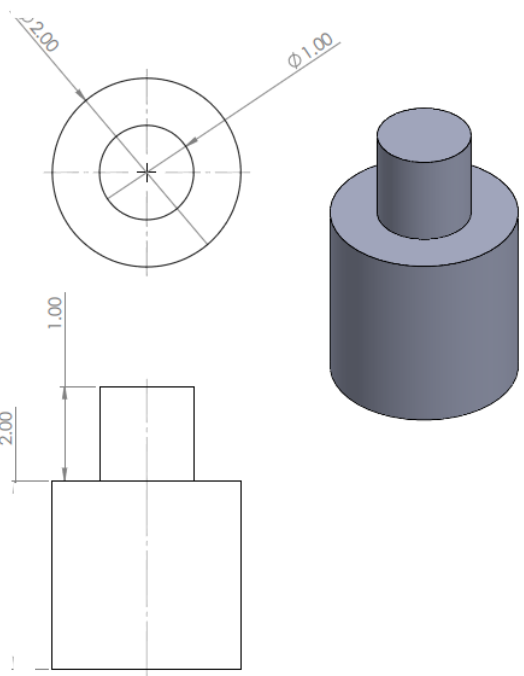

Create the Cylinder using the Revolve Feature

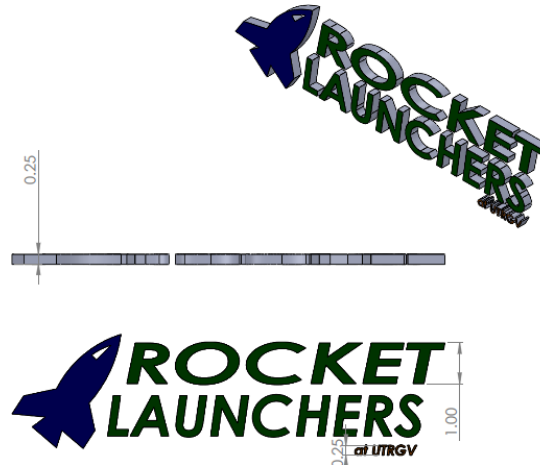

Use the Text Sketch tool to create a Logo that can be extruded slightly. Include a simple shape to make it stand out